

## VS-09-SET-EMV

Order No.: 1689158

<http://eshop.phoenixcontact.de/phoenix/treeViewClick.do?UID=1689158>

D-SUB connector set, shell size 1, IP67 protection, with shrouds

### Commercial data

EAN	4017918890568
Pack	1 Pcs.
Customs tariff	85369010
Weight/Piece	0.0781 KG
Catalog page information	Page 222 (PC-2007)

### Product notes

WEEE/RoHS-compliant since:  
06/02/2006

<http://www.download.phoenixcontact.com>  
Please note that the data given here has been taken from the online catalog. For comprehensive information and data, please refer to the user documentation. The General Terms and Conditions of Use apply to Internet downloads.

### Technical data

#### Mechanical characteristics

Ambient temperature (operation)	-40 °C ... 80 °C
Insertion/withdrawal cycles	≥ 1000
Cable exit	Angled
Color	Squirrel gray RAL 7000
Shielded	Yes
External cable diameter	3 mm ... 9 mm

**Material data**

Housing material	PA
Seal material	Flat gasket: NBR; profile gasket: EPDM
Cable seal material	CR/NBR
Degree of protection	IP67
Inflammability class acc. to UL 94	V0

**Drawings**

Dimensioned drawing

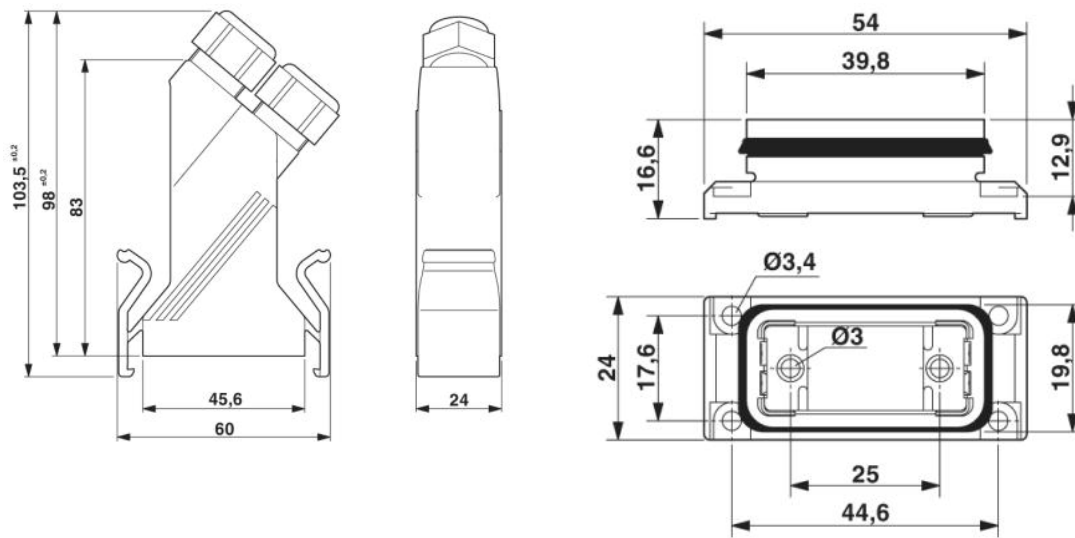

**Address**

PHOENIX CONTACT Inc., USA  
586 Fulling Mill Road  
Middletown, PA 17057, USA  
Phone (800) 888-7388  
Fax (717) 944-1625  
<http://www.phoenixcon.com>



© 2008 Phoenix Contact  
Technical modifications reserved;